

Design and Development of Pulse Detonation Rocket Engine with Predetonator

Bhavesh Singla¹ and Linsu Sebastian²

¹Student, Department of Aerospace Engineering University of Petroleum and Energy Studies, Dehradun-248007

²Department of Aerospace Engineering University of Petroleum and Energy Studies, Dehradun-248007

E-mail: ¹bhaveshsingla2137@gmail.com, ²lsebastian@ddn.upes.ac.in

Abstract: Pulse Detonation Engines (PDE's) represent an upcoming new approach to propulsion and with the simplicity of its construction; PDE's produce thrust more efficiently than the current engines and produces a higher specific thrust. Since current rocket engines require heavy and expensive pumps; with mechanical simplicity and thermodynamic efficiency PDE's offer a viable alternative to reduce the cost of launching spacecraft. Since the obstacles used in Deflagration-to-Detonation Technique (DDT) not only helps in detonation formation but also provides drag to the detonation wave hence formed and also leads to increase in weight, if considering a large main detonation tube. So the concept of predetonator came into, which provides a viable alternative as a small confined area is restricted for detonation formation at the expense of a small amount of extra fuel and oxygen. The PDRE used here is a 30mm inner diameter main detonation tube with 800mm length and a predetonator tube of 30mm diameter and 560mm length. A multishot detonation engine was designed with liquid Kerosene, Gaseous Oxygen, and Nitrogen were used as fuel oxidizer and purge gas. A further development in predetonator was done by increasing the effect of detonation in predetonator by using C-D nozzle to increase the velocity of detonation wave hence formed which is then ejected into main detonation tube.

1. INTRODUCTION

Detonation is a self-sustaining combustion process that leads to the formation of supersonic combustion products. The wave front produced by the detonation process, is at supersonic speeds, which compresses the unburned fuel and mixture ahead of the wave front. This further compresses the unburned fuel-oxidizer mixture and leads to detonation. Whereas In the process of deflagration the burning of fuels through flames will be moderately simple and gentle and the under the similar condition we observe that main typical that is nothing but the travelling characteristics of this flame will be at subsonic stage. On comparison of deflagration and detonation, detonation is found to be more effective in the terms of pressure and velocity obtained.

Table 1: Different Values of Detonation and Deflagration [8]

	Detonation	Deflagration
u_1/c_1	5-10	0.0001-0.03
u_2/u_1	0.4-0.7(deceleration)	4-16

p_2/p_1	13-55(compression)	0.98-0.976(slight expansion)
T_2/T_1	8-21(heat addition)	4-16(heat addition)

So detonations are more efficient means of combustion. For past 80 years research has been going on for incorporating detonation as a means producing thrust. Detonation basically can be judged on two parameters Chapman-Jouguet (CJ) velocity and CJ pressure, which can be analytically derived by following the condition of perfectly mixed fuel and air mixture in gaseous state [1].

From past 2 decades Pulse Detonation Engine has seen quite a lot of improvement and much consideration. Pulse Detonation Engine is a pulsed propulsion device in which the product gases are produced by detonation of fuel and oxygen in the combustion chamber, which is intermittently filled with fuel and oxygen. The pressure and velocity of the combustion products produced by the detonation are expanded out to give thrust. Pulse Detonation Engine (PDE) is highly emerging detonation technique. With its mechanical simplicity and its advantage in lowering cost, weight and complexity, various models have been proposed for military, civil as well rocket and spacecraft propulsion applications. Basic strength of the PDE is based on the volume of the detonation tube and number of pulse cycles that are produced i.e. the frequency of the PDE. One of the challenges in development of PDE is the Detonation initiation and cycling. Detonation can be initiated using two methods; DDT & Shock to Detonation Technique (SDT) which requires a long length tube and obstacles to initiate detonation; and the other one is direct detonation which requires high amount of energy to be focused on a particular point on tube and depends on cell size, cell width and chemical nature of the mixture. Direct detonation is not preferred due to high energy requirement, approximately 26,000J [2]. Cycle time period also plays a major role in determining the effectiveness of the PDE. Lower the time period of a cycle i.e. greater the frequency of the cycles more is the effectiveness of the PDE.

The objective of this paper is to eliminate the need for longer DDT sections, which is very important for the practical realization of Pulse Detonation Rocket Engine (PDRE). Decrease the complete drag of the mass flow through the engine by developing a new geometry. A practical PDE must operate at frequencies high enough to generate thrust and reducing the overall drag will allow to maintain high efficiencies at higher operating frequencies and to ensure the transition of detonation waves into the main core of the engine. This transition should occur with minimal weakening of the detonation wave.

This was achieved by the utilization of a Predetonator, which is a small chamber in which detonation is accomplished by the use of DDT or SDT which is then transferred to the main chamber to achieve detonation and produce thrust.

In addition to the mentioned objectives nozzles were also as a method of enhancing performance of PDRE. By the literature review it was found that the bell-shaped nozzles were found to be better at performance enhancement. On further review it was found that converging-diverging nozzles enhances the performance in much better way comparing with other kind of nozzles [1].

2. PREDETONATOR

A predetonator is very valuable as a small amount of fuel and oxidizer are together burned so as to produce a detonation wave which when passed on to the main detonation chamber causes detonation in the main chamber and hence helping the decrease in net DDT length. It can be visualized as a small PDE utilized for the Detonation formation in the main larger detonation engine.

How predetonator is useful? It can be easily answered by stating that the detonation can be accomplished very easily the utilization of an already present detonation wave. This concept of utilizing detonation wave to cause detonation in other chamber is very popular in the respect that it is not only limited to the use in predetonators but also used in various other designs like in one two tube PDE the detonation is produced in one tube using DDT and a part of detonation wave is then transferred to other tube which causes the formation detonation wave in other tube and both the tubes are utilized for producing thrust intermittently.

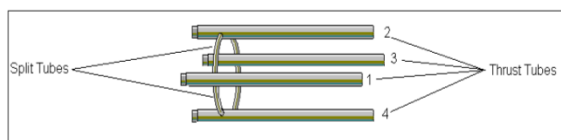

Fig. 1: Concept art for integrated PDE system [8]

So predetonator is much more useful for rocket engines in the way that it not only decreases the run up distance that is utilized in DDT by decreasing the amount of fuel and oxygen that is to be detonated but also it decreases the overall weight of the PDRE the reducing the weight of the obstacles [2]. And it is better than direct initiation technique in the way that such large energy is not required for detonation.

One of the drawbacks or setbacks of utilizing Predetonator is that some extra fuel and oxygen is utilized and which leads to decrement in its specific impulse [8]. But the advantages of predetonator are far better to overlook, so utilization of the predetonator in PDRE has always been a topic of research in the scientific community.

2.1. Deflagration-to-Detonation Technique (DDT)

To design a predetonator it is very important to produce detonation wave in the chamber, which can be accomplished by two techniques either by utilizing DDT or by Direct Initiation which requires approximately 12,000J of energy. So our main area of focus is DDT.

DDT is a process in which combustion is initiated by weak source of ignition which causes deflagration. This subsonic deflagration wave undergoes and a series of gas dynamic processes to reach a supersonic wave velocity or detonation velocity.

Since this procedure is time consuming and requires a long length of combustion chamber so additional obstacles are added in the combustion chamber so as to lead to detonation much faster.

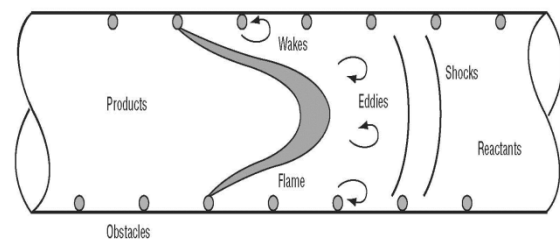

Fig. 2: Illustration of Schielkin spiral and its effect on turbulence mixing and flame acceleration

As illustrated in Fig. 2, the weak ignition source causes deflagration in fuel-oxidizer mixture which causes the formation of compression waves and turbulent flow ahead of deflagration wave because of the use of the obstacles. These compression waves compress the fuel and oxidizer mixture to such an extent it causes the detonation initiation which further stabilizes into a detonation wave.

So use of the obstacles in DDT causes the formation of detonation wave in much compact length and with ease, without utilizing high energy source. The main disadvantage of utilizing the obstacles is the added weight of obstacles in the PDRE and also the use of obstacles causes the decrement in the velocity of the detonation wave by the increasing the drag.

3. DESIGN CONSIDERATIONS

From the above discussion we know that Pulse Detonation Rocket is much more efficient and advantageous than conventional rocket engine. So, design of a pulse detonation rocket engine is to be taken into account.

3.1 Predetonator Design

Predetonator being the one of the most important component of this project was designed first.

3.1.1 Diameter of Predetonator

Diameter of the Predetonator is of quite importance as it affects the shape of the detonation wave hence formed. It actually depends on the cell size of the fuel oxidizer mixture.

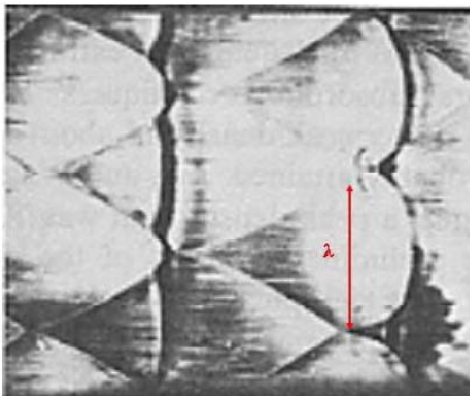

Fig. 3: Three dimensional Detonation wave structure [8]

A spherical wave front is most favorable as it has lower pressure and friction losses. So for a spherical wave front to be formed [11]

$$E = 13 \lambda \tag{1}$$

Where, λ= cell size

3.1.2 Obstacle design

Obstacles design is a critical part of detonation and quite a lot of research is going on in the obstacle design. By the literature review and the going through all the researches an outline of the obstacle was established with required parameters. The

obstacle design was taken from the concept of schileken spiral which has been proved and established experimental considerations have been put forward.

For obstacle design, one the most important parameter is the blockage ratio (B.R.). Blockage ratio is defined as the amount of blockage applied by the obstacles to the flow. It is given by the formula [4]:-

$$B.R. = 1 - (D_{\text{orifice}} / D_{\text{tube}})^2 \tag{2}$$

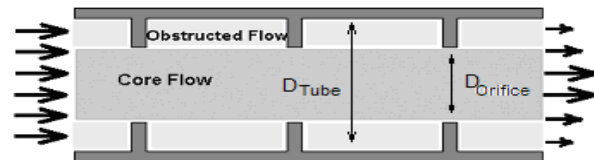

Fig. 4: Schematic diagram defining core flow [4]

Next, the spacing between the obstacles and the length of the DDT chamber is also taken into account.

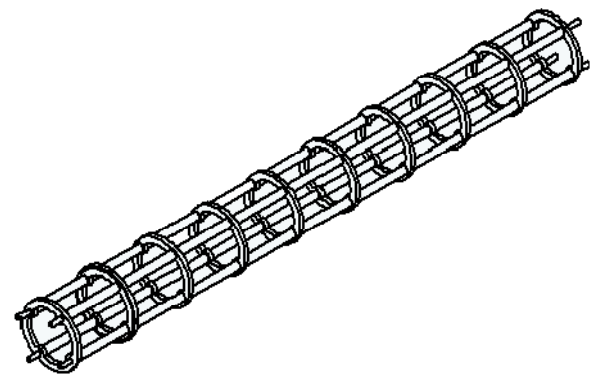

Fig. 5: Obstacle geometry

These all design considerations were taken into account and established from predefined experimental results and conclusions.

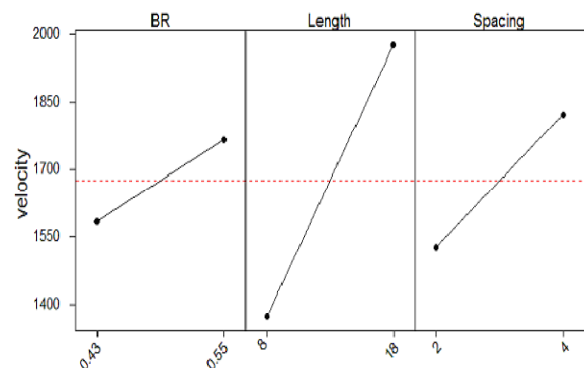

Fig. 6: Effects of obstacle geometry parameters on PDRE [4]

3.1.3 Injector Design

Sine liquid fuel consumes is more practical and has higher density, so, liquid fuel and oxygen were considered for the PDRE. But the main problem with liquid fuel is mixing of liquid fuel and gaseous oxygen, which require atomization of fuel into minute droplets with droplet size in μm . This poses problem. Extensive research is going for the atomization, mixing and injection fuel and oxidizer in the chamber.

Most of the studies were based on premixed fuel- oxidizer mixture and that was kept as the basis of mixing. Also swirl injectors were widely used for two phase mixing but due to manufacturing difficulties and based on earlier researches and experimental investigations simple premixed injectors were used instead of swirl injectors. The injector design used was taken from already established experimental research [1] which showed promising results.

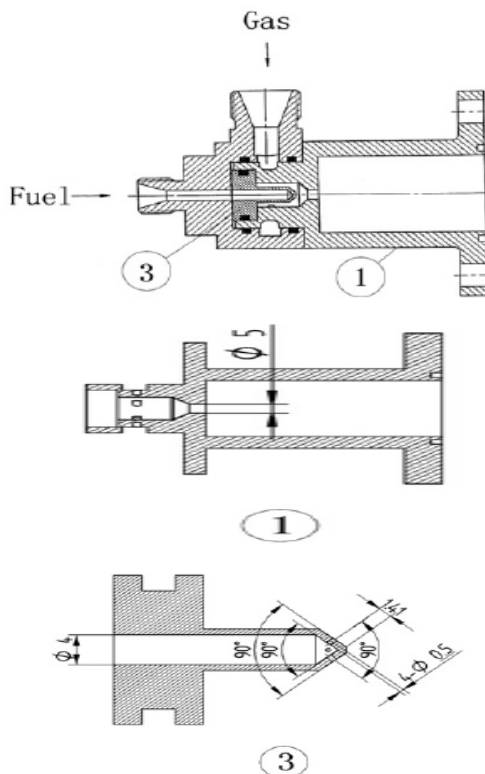

Fig. 7: Injector Design [1]

3.1.4 Nozzle Design

Nozzles are a method of enhancing performance of the predetonator. In previous researches it has been established that Bell shaped Converging- Diverging nozzles provide the best performance enhancement [1]. So in this Bell shaped Converging-Diverging nozzle is only considered for predetonator so as to increase the detonation velocity and pressure in the main detonation tube chamber.

For this project, the nozzle was design was taken through literature review and already established research by Wei Fan et al [1]. It provides optimum velocity and pressure enhancement.

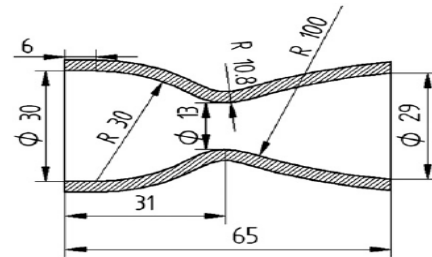

Fig. 8. Nozzle Design [1]

3.1.5 Consideration for Cyclic Detonation

Since a rocket requires continuous thrust for its operation so cyclic detonations are necessary for the development of PDRE. Cyclic detonations differ from Single shot detonations in a way that automatic control of fuel and oxidizer should be there intermittently with the ignition spark. Also the interactions of burned products and the incoming fuel and oxidizer should be taken into account.

Now, since the burned products are at very high temperature, so immediate injection of fresh fuel and oxidizer may lead to preignition which will result in deflagration and detonations hence will not be formed. So a purge gas is added into the chamber after the detonations, so as to remove the burned products from the detonation chamber. This purge gas used is inert in nature. The quantity of purge gas used depends on the user and the system.

4. EXPERIMENTAL APPARATUS"

On the basis of the above mentioned considerations, development of experimental setup was taken ahead to study the effect of predetonator in Pulse Detonation Rocket Engine. The test model consists of fuel and air supply system, predetonator, nozzle, main detonator and pulse spark generator. Fuel pump was used to supply fuel to injector and a compressed oxygen cylinder was used to supply oxygen. Compressed nitrogen cylinder was used to supply nitrogen as a purge gas. Solenoid valves were used to supply fuel and oxygen intermittently to injector. The test model was suspended on the test bed and static testing was done. Liquid Kerosene was used as fuel and gaseous oxygen was used as oxidizer. The air fuel entered the predetonator and the main detonation tube through the injector design, which can generate droplets with about $80\mu\text{m}$ diameter. The experimental apparatus also allowed the control of the operating parameters. The ignition spark frequency and the solenoid valves were controlled by micro controlled signal generator. The Ignition spark used in this project provided the ignition energy of 50mJ. The predetonator and main

detonation tube with obstacles and nozzle was constructed from steel and the injectors were cut out from bronze. For the predetonator design the inner diameter was taken 30mm.

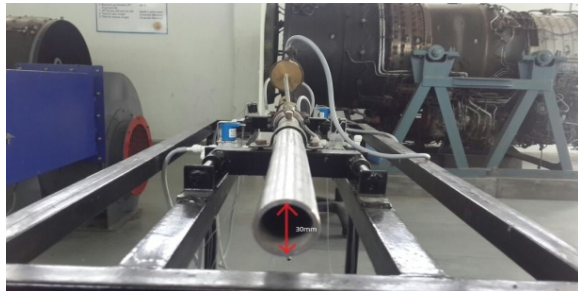

Fig. 9: Inner diameter of the predetonator

The obstacle blockage ratio was taken 0.43 and obstacle length and spacing of 30mm. Six obstacles were used to form predetonation chamber.



Fig. 10: Obstacle CAD drawing

The predetonator was divided into three segments:-first section was mixing and initiation chamber whose length was 100mm from the injector and with a spark plug situated at 50mm from the injector. The next section is the DDT chamber which consists of the obstacles with the total length of 330mm. the next part was propagation chamber with a total length of 70mm. So the total length of predetonator is 500mm.

The nozzle was used according to specifications discussed. He main detonation chamber had its injector section 50 mm away from nozzle end and inclined 30 degrees to the body. The total length of the main detonation tube was 520mm.

Finally, a PDRE with predetonator and 1Hz frequency was developed. The timings for solenoid valves were setup.

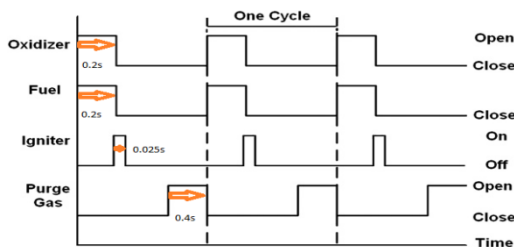

Fig. 11: Timing Diagram of Solenoid Valves



Fig. 11: Experimental Setup

5. EXPERIMENTAL CONDITIONS

For all the experiments, the initial pressure was kept at 1atm and initial temperature at 25°C. The mixture equivalence ratio was kept 1.72 [1] and mass flow rates of fuel and oxygen were kept 10.38g/s and 20.87g/s [1].

6. RESULTS AND DISCUSSIONS

Using NASA CEA Code and by doing the mathematical Calculations initial result of detonation parameters for kerosene fuel and oxygen, were setup i.e. CJ velocity and CJ Pressure were 2356m/s and 4.18MPa respectively at 1 equivalence ratio. Now by the literature review and by doing CFD analysis of the system it was found out that detonations occurred in the predetonator tube and which when passed through the nozzle system lead to 27% increase in the detonation wave characteristics [1]. Also perfect detonations were achieved in the main detonation tube.

7. FUTURE WORK

Future work of this project is to work on various other obstacle designs and nozzle designs for the enhancement of the predetonator and decrement of the predetonator length. Also the concept of multiple predetonators for detonation in a large main detonation chamber is being looked.

8. ACKNOWLEDGMENT

We would like to thank our university for providing the opportunity to work on the project. We would also like to thank all our colleagues, especially Ajeet Sakar, Navneet Kumar, Nitin Kukreja and Manoj Joishi, without whom the project would be incomplete. Also we would like to thank Mr. Kartik Sundarraj, who helped us throughout with the CFD analysis.

9. REFERENCES

[1] Yu Yan, Wei Fan, Ke Wang, Xu-dong Zhu & Yang Mu, "Experimental investigations on pulse detonation rocket engine"

- with various injectors and nozzles*", School of Power and Energy, Northwestern Polytechnical University, Xi'an, 710072, PR China, 29 March 2011
- [2] Wei Fan, Chuan Yan, Xiqiao, Qun Zhang and Longxi Zheng, "*Experimental investigation on two-phase pulse detonation engine*", School of Power and Energy, Northwestern Polytechnical University, Xi'an, 710072, PR China, 5 february 2003.
- [3] S.M. Forlov," *Pulse Detonation Propulsion*", N. Semenov Institute of Chemical Physicss, Moscow, RUSSIA
- [4] David M Chapin, *A Study of Deflagration to Detonation transition in a Pulsed Detonation Engine*, Georgia Institute of Technology, USA, Master's Thesis, 2005.
- [5] E. Wintenberger and J.E. Shepherd," *Detonation waves and Pulse Detonation Engines*", Explosion Dynamics Laboratory, Graduate Aeronautical Laboratories, California institute of Technology, Pasadena, CA 91125 ,Ae103, January 27 2004
- [6] August J. Rolling," *Alternative Pulse Detonation Ignition System Investigation Through Detonation Splitting*", Air Force Institute of Technology, USA, Master's Thesis, March 2002.
- [7] Tad J. Robbins, *Fuel injection strategy for a next generation Pulse Detonation Engine*, Naval Postgraduate School, Monterey, California, Master's Thesis, June 2006.
- [8] Philip D. Hall, *Design of coaxial split flow Pulse Detonation Engine*, Naval Postgraduate School, Monterey, California, Master's Thesis, June 2006.
- [9] Piotr Wolanski," *Detonation Engines*", Institute of Aviation Al. Krakowska 110/114, 02-256, Warsaw and Institute of Heat Engineering, Warsaw University of Technology Nowowiejska 21/25, 00-665 Warsaw.
- [10] Matthew Lam, Daniel Tillie, Timothy Leaver and Brian McFadden," *Pulse Detonation Engine Technology: An Overview*", Applied Science 201, University of British Columbia, November 26 2004
- [11] Phillip K. Panicker, Jiun-Ming Li, Frank K. Lu and Donald R. Wilson," *Development of a Compact Liquid Fueled Pulsed Detonation Engine with Pre-detonator*", University of Texas, Arlington, 8 March 2007